

FOR063

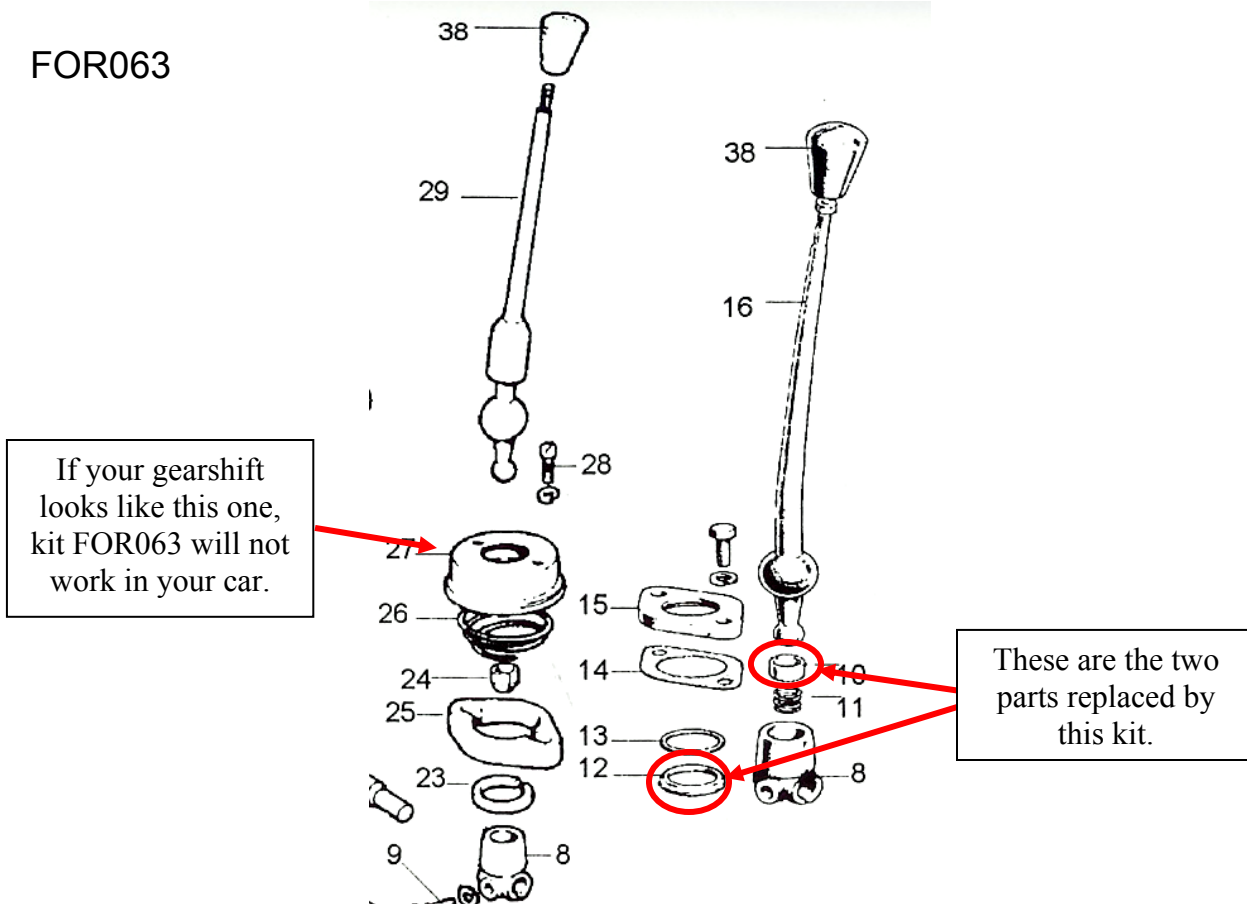

Instructions for Installing Gearshift Lever Teflon Bushing and Top Spacer

The bushing and top spacer in this kit are made of quality mechanical grade Teflon. As such, it has the good characteristics of being non-corrosive, impervious to grease and oil, durable and self-lubricating unlike any other material. Please completely read and follow the installation instructions below:

1. Remove the gearshift lever boot.
2. Remove the gearshift lever.
3. Remove old bushing that contacts the bottom of the lower ball of gearshift lever from the remote linkage.
4. Install the new bushing with the shoulder up into the remote linkage.
5. Remove any old spacers from the top of the upper ball on the gearshift lever.
6. Remove the gearshift lever knob, boot, etc. and slip the top spacer over the top of the gearshift lever onto the large upper ball of the gearshift lever.
7. Alternately, if the gearshift knob will not come off, you can split the spacer (one cut only) with a hacksaw and then spread the new Teflon spacer with your fingers and slip it onto the top of the upper ball of the gearshift lever. Reinstall the gearshift lever. A small amount of force may be required to seat the lower gearshift lever ball into the bushing in the remote linkage, as the tolerances are close so as to eliminate the annoying vibration and noise that is common with this gearshift design.
8. Reinstall the gearshift lever boot.